



OIL COOLING SYSTEMS

Oil Cooler Installation Guide

Fits Models: RF-1 FLH 1999-2008 Reefer Cooler
RF-2 FLH 2009-2015 Reefer Cooler



Patent #6955150

Welcome to UltraCool

We would like to thank you for making UltraCool your system of choice. We have countless hours into these instructions to make your installation as easy as possible. If you have any questions or comments, please contact us at (831) 630-1322 or email us at info@ultracoolfl.com. Again, Thank you.

Important please read below.

Please read through the entire installation process before you start the installation. If you think you are not capable, please call and we will find a dealer near you who can install it for you.

Let's get started.

Below you will find a list of tools required for installation. Make sure these are available before you start. Please inventory your kit before you start installation.

Tools Required

- Open end wrench 7/16"
- Open end wrench 11/16"
- Ratchet
- Ratchet extension 8"
- 1" deep socket
- Torx # 27
- Torque wrench - ft lbs.
- Oil filter wrench
- Allen diver 5/32"
- Hex driver 7/16" - Step 2
- Socket 7/8" - Step 3
- Power drill
- Drill bit 5/16"
- Flashlight
- Wire strippers

Kit Includes:

- Complete fan assembly - boxed
- (2) Braided oil lines - poly bag
- Steel mounting bracket - poly bag
- Oil adapter - boxed
- Parts bag - poly bag
- Installation guide

Parts Bag

- Adapter key - RF-1 ONLY
- L.E.D. light kit
- Fitting wrench
- Thread locker
- (6) Tie straps
- Threaded adapter - Step 3
- Wiring harness

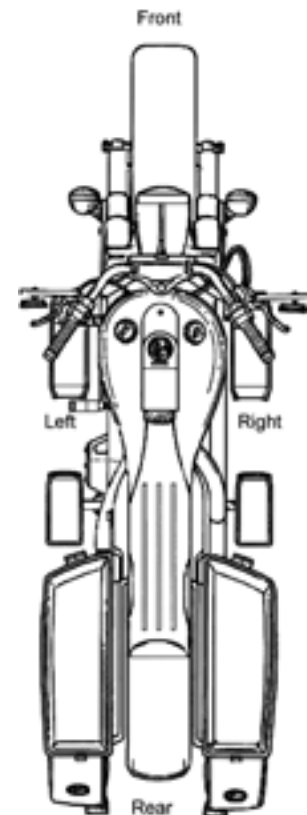

Instructions are explained and illustrated from a riders point of view.

Cooler on Bike Now

If you have stock cooler or any other manufacturers cooler on your bike, you will need to remove this before you start the Ultracool installation. Refer to your owner's manual for help with this removal.

If you **have a stock or existing cooler** on your bike, complete steps 1-2-3 and so on.

If you **do not have a cooler** on your bike, complete steps 1-4-5 and so on.

Step 1

Remove Oil Filter

Remove your oil filter and clean up any excess oil. The surface needs to be clean and oil free.

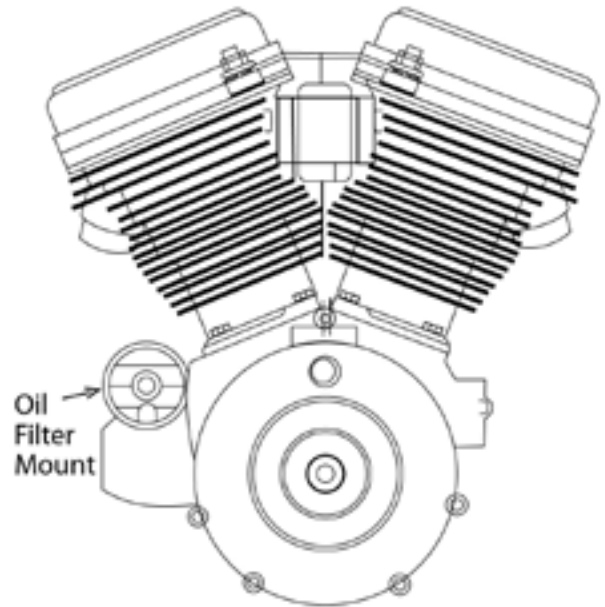

Step 2

Remove Old Cooler

If you have a stock cooler on your bike you can remove it by taking out the $\frac{7}{16}$ " Allen nut in the center of the oil adapter.

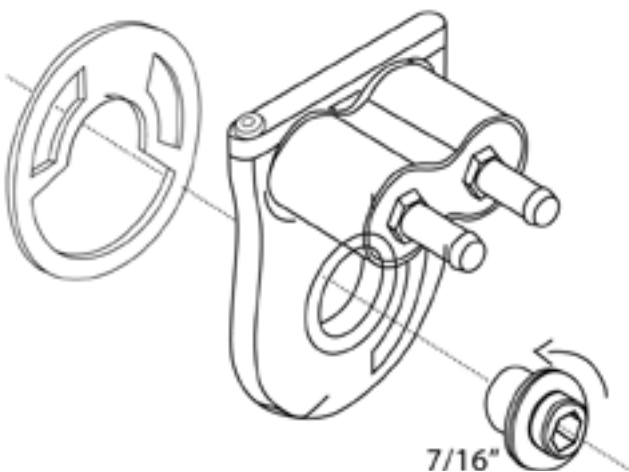

Step 3

Install Threaded Adapter

After you have removed the old adapter, locate the threaded adapter and add 3 drops of thread locker, then install in the center of the filter mount and torque to 15 foot lbs.

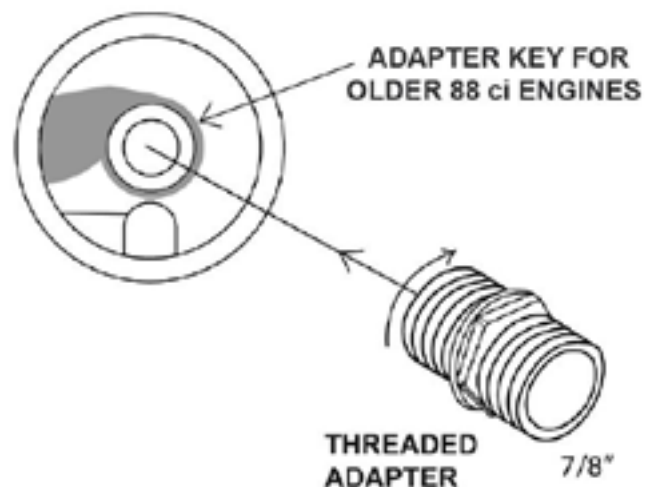

Step 4

Oil Adapter Installation

Locate the oil adapter and take it to a clean surface. Using a $\frac{5}{32}$ " Allen driver remove the 6 bolts from the front as shown. Watch out for small washers! **Note: There are (4) $1\text{-}\frac{1}{8}$ " and (2) $\frac{3}{4}$ " bolts and (6) washers.**

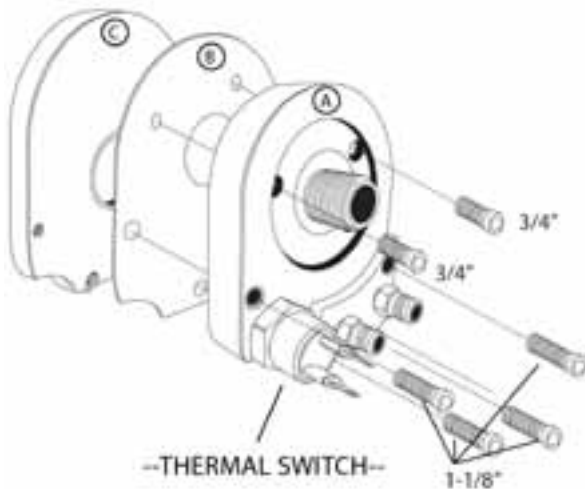

Step 5

Notice that parts of the adapter are marked A-B-C. Take part C and look on the back, there are two alignment cams. Place part C over the oil filter mount in the 11:00 position. Now take the 1" nut and add a few drops of thread locker, tighten to threaded adaptor on oil filter mount and torque to 20 foot lbs.



Step 6

Locate parts A and B of the oil adapter, (2) $\frac{3}{4}$ " bolts and washers. Screw the bolts in the top as shown. This will hold the gasket in place. Now hand start to plate (C). Use a $\frac{5}{32}$ " Allen driver - just hand tight. Get the (4) $1\text{-}\frac{1}{8}$ " along the bottom and hand tight.

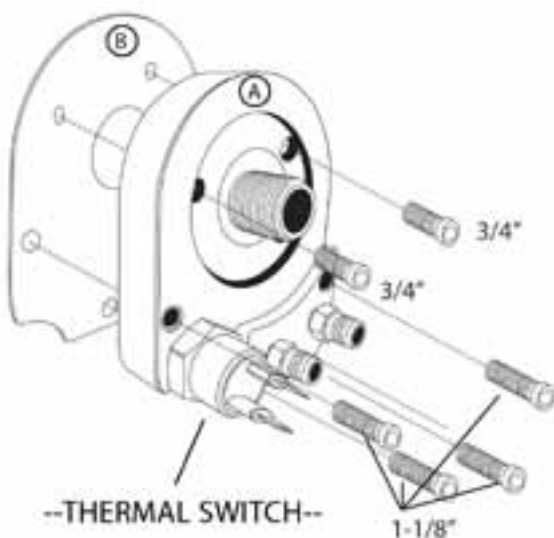

Step 7

Now all of the bolts and washers are installed and hand tight. Use a torque wrench and set it to 6 foot lbs and tighten as shown.

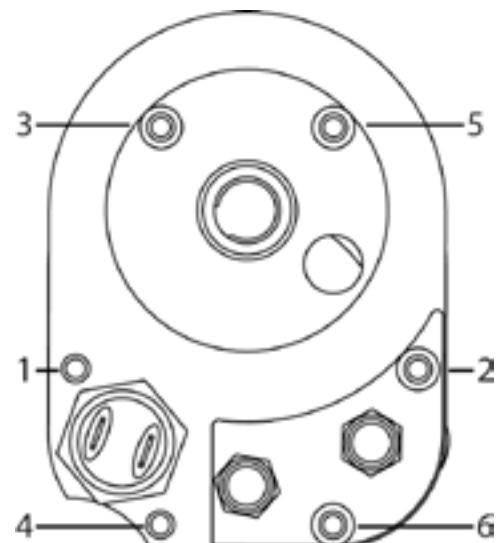

Step 8

Install Mounting Bracket

Locate the mounting bracket. Remove the (2) 7/16" nuts holding the voltage regulator to the frame. Lift the regulator off the studs and slide the mounting bracket over the studs then place the Regulator over bracket. Use thread locker on nuts and tighten.

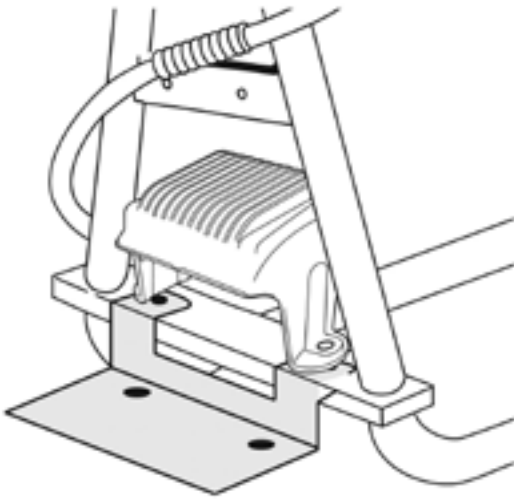

Tech Tips:

...Split Rubber Hoses

Make sure you use the split rubber hose pieces to protect the oil lines from chaffing or rubbing on the frame or electrical wires. They are there for a reason.

...Hose Fittings

Use 3-4 drops of oil on the inside of the fittings. This will make them go on easier and make a better seal.

...Pre-bend the Hoses

If you flex the oil lines not more 180 degrees this make it easier to install and fit.

For RF-1 Hose Installation go to step 9
For RF-2 Hose Installation go to step 17

RF-1 Hose Installation

Step 9

Identify Hose Numbers & Fittings

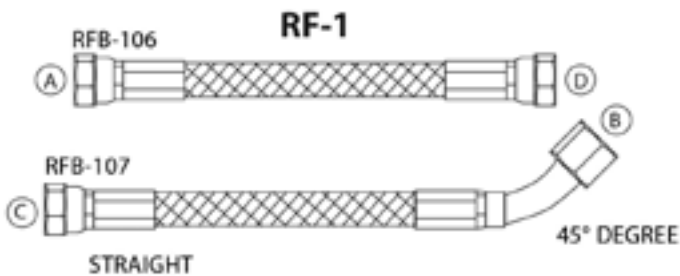

Step 10

Remember this is from a rider's point of view.

- Locate cooler assembly and remove chrome cover
- Remove plastic debris caps
- Take cooler assembly and hoses to a bench

RF-1 Hose Installation

Step 11

- Locate hose RFB-106 oil fittings now
- Attach straight fitting to LEFT side AN-6 on cooler
- Make sure it goes on smooth just hand tight

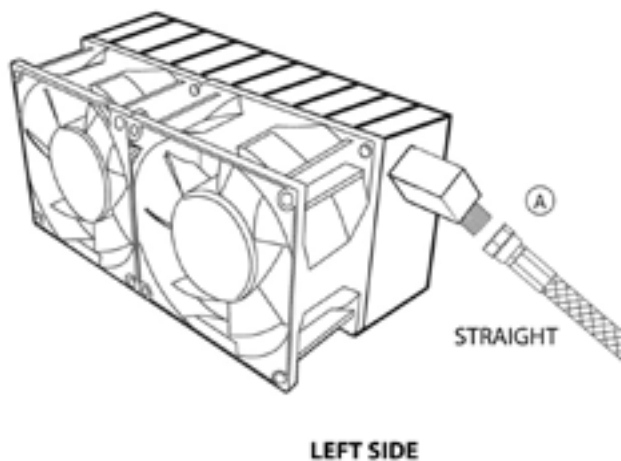

Step 12

- Locate hose RFB-107 oil fittings now
- Attach 45 degree fitting to right side AN-6
- Make sure it goes on smooth. Just hand tight

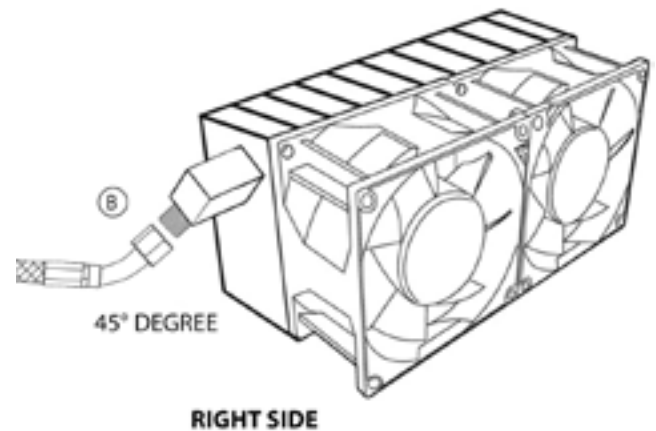

Step 13

Mount Cooler Assembly & Hoses

Place cooler assembly with hoses attached to front mounting bracket and secure it with 1 of the chrome cover bolts. Just hand tight.

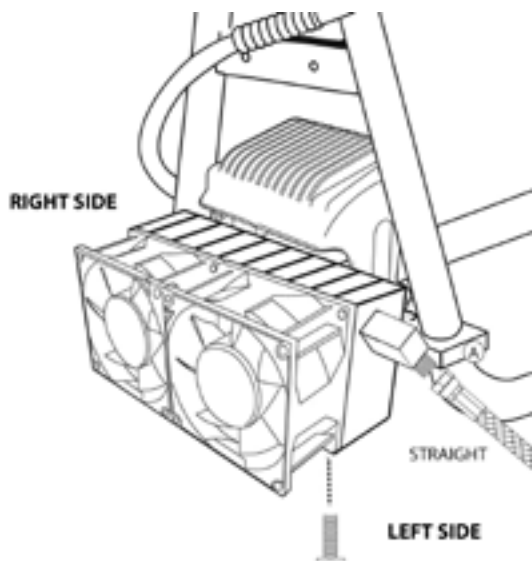

Next we will be routing the hoses.

Now is a good time to grab some tools you will need:

- Fitting tool from parts bag
- Ratchet extension 8"
- Tie straps
- Diagonal cutters
- Flashlight
- Ratchet
- Rubber hose pieces

RF-1 Hose Installation

Step 14

Routing Hose RFB-107

Go over to the right side of the bike and run the line behind the mounting bracket and up by the shift lever and connect to the rear AN-6 fitting on the oil adapter. Hand start and then tighten with tools.

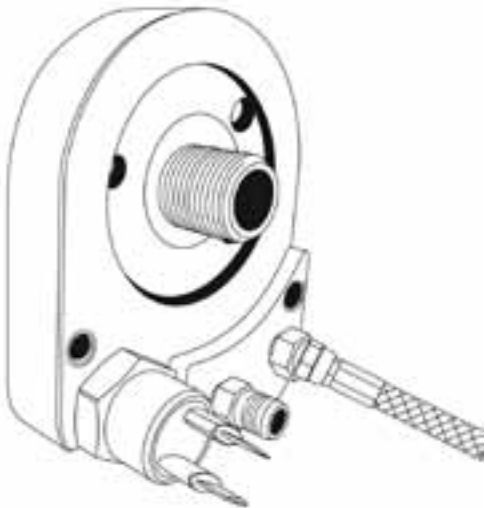

Step 15

Routing Hose RFB-106

On the left side run the line under the frame cross member and up by the shift lever and come up to the front AN-6 on the oil adapter. Then tighten with tools.

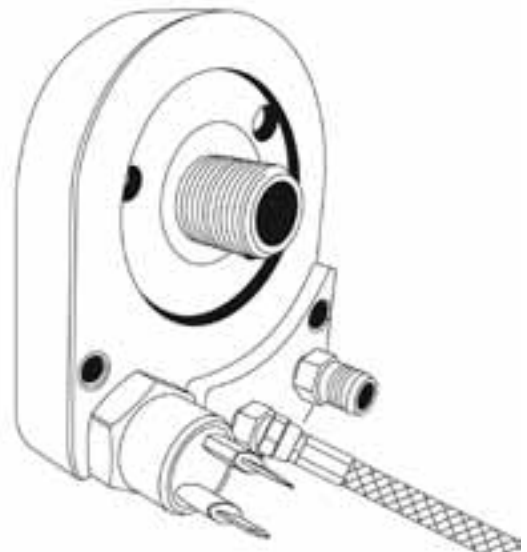

Connecting the Oil Lines

Note the angle of the oil lines. This should be close.

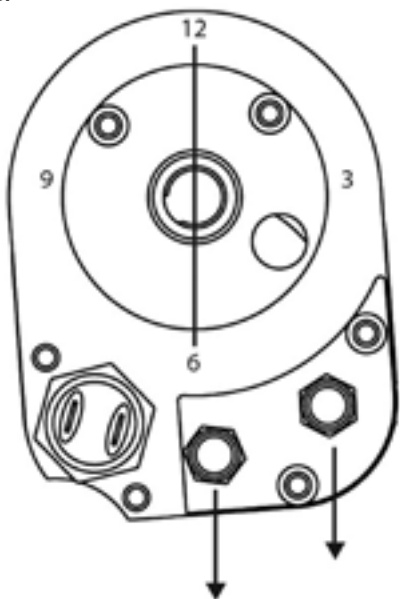

Step 16

Tightening Fittings

After all fittings are connected check for any rubbing on frame or electrical wires. Use split rubber pc to address with a tie strap.

Locate fitting wrench, ratchet and ext. slide fitting Wrench over hose and up to fitting to be tightened. Attach ratchet and ext and start to make small turns Reposition tool. Bring it up snug and turn 1 more flat. This should be tight. Repeat this to all fittings. **Note: RED bullet connector on right side.**

End of RF-1 Hose Installation

RF-2 Hose Installation

Step 17

Identify Hose Numbers & Fittings

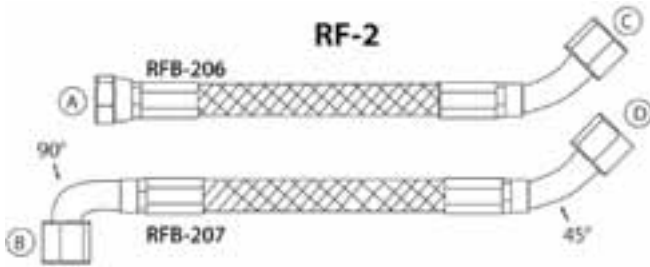

Step 18

Remember this is from a rider's point of view.

- Locate cooler assembly and remove chrome cover
- Remove plastic debris caps

Step 19

Locate hose RF-206 and attach 45° fitting to Rear AN-6 on oil adapter. Make sure it goes on smooth. Just hand tight using fitting tool.

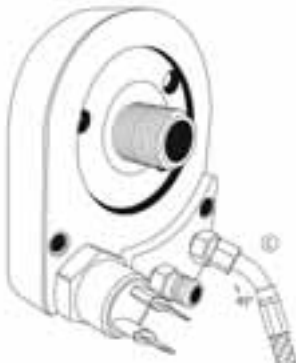

Step 20

Locate hose RF-207 and attach 90° fitting to Front AN-6 on oil adapter. Make sure it goes on smooth. Just hand tight using the fitting tool.



Step 21

Mount Cooler Assembly

Place cooler assembly on mounting bracket. Use 1 chrome cover bolt to hold it in place.

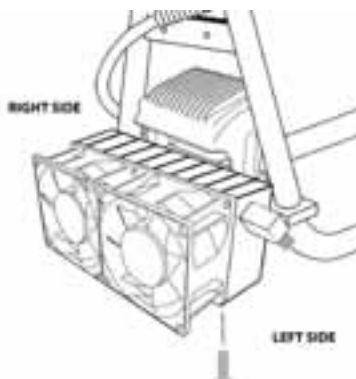

Next we will be routing the hoses.

Now is a good time to grab some tools you will need:

- Fitting tool from parts bag
- Ratchet extension 8"
- Tie straps
- Diagonal cutters
- Flashlight
- Ratchet
- Rubber hose pieces

Connecting the Oil Lines

Note the angle of the oil lines. This should be close.

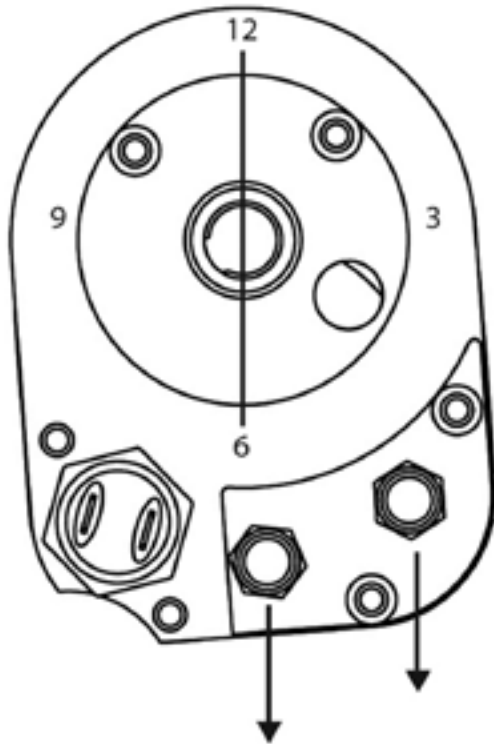

Step 22

Hose RFB-206

Run hose RFB-206 down and come up to AN-6 fitting on cooler. It makes a loop up to the cooler. Hand start to fitting.

Use a back up wrench 11/16" on the cooler core fitting to prevent damage.

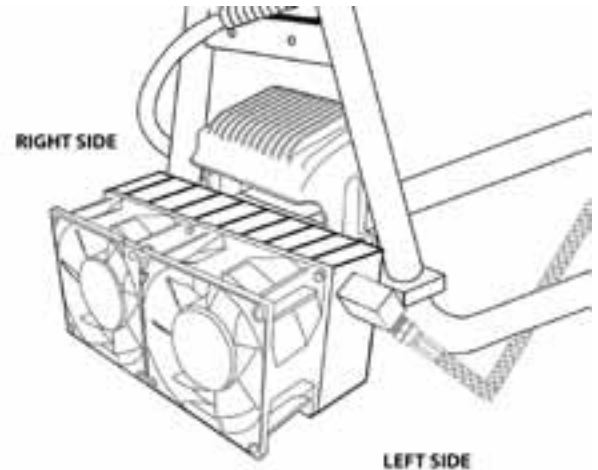

Step 23

Hose RFB-207

Run hose down and to the right behind the mounting bracket and over to AN-6 fitting on cooler core. Hand start to fitting.

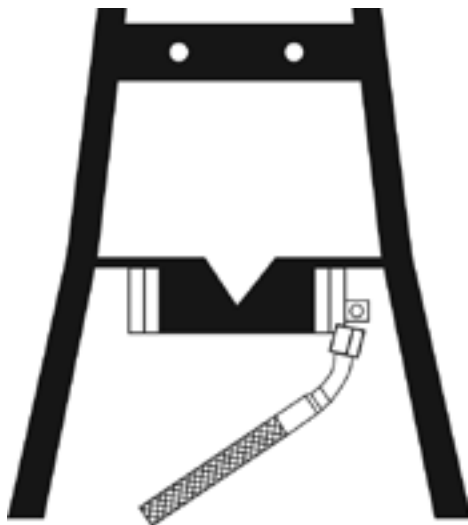

Step 24

Tightening Fittings

After all fittings are connected check for any rubbing on frame or electrical wires. Use split Rubber pc to address with a tie strap.

Locate fitting wrench, ratchet and ext. slide fitting wrench over hose and up to fitting to be tightened. Attach ratchet and ext and start to make small turns reposition tool. Bring it up snug and turn 1 more flat. This should be tight. Repeat this to all fittings.

Note: RED bullet connector on right side

Use a back up wrench 11/16" on the cooler core fitting to prevent damage.

Harness & Connectors

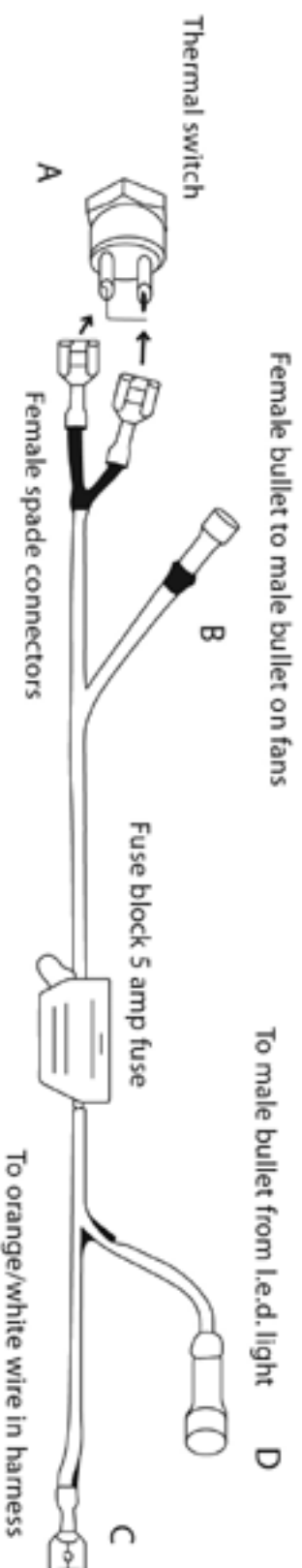

FLH-2014 Electrical Connection

BLACK WIRE

Connect to L.E.D. black wire. Use supplied Female spade connector.



RED WIRE.

Connect to (C) on harness (male spade)

L.E.D. RED Wire

Connect to (D) on harness.

UltraCool RF-2 will fit on all FLH models

(BUT NOT THE Ultra Limited)

To connect to power order this switch in the RF-2

Parts online. RF-155 \$7.50

Remove 7 torx from front fairing. Disconnect headlight and set to the side. On the right side look for a 1" square connector by the voltage gauge. It could be tucked back in.

RED WIRE

Connect to © On harness (*male spade*)

BLACK WIRE

Connect to L.E.D. black wire. Use supplied Female spade connector.

L.E.D. RED WIRE

Connect to (D) on harness.

Step 25

Connecting to Power

Next we will be connecting to power and installing the L.E.D. light. **Listed are the tools that you will need:**

- Wire strippers
- Power drill
- Terminal crimpers
- 5/16" drill bit
- Ratchet
- Flashlight
- Torx 27#
- Tie straps

Step 26

Getting Started

- Remove 7 torx from fairing.
- Disconnect headlight connector.
- Set fairing to the side.
- Locate wiring harness in parts bag.
- Identify connections below in the drawing.
- A.** Connect 2 female spades to thermal switch any side is ok.
- B.** Connect RED female bullet to RED male bullet on right side of cooler assembly. Fan power lead.
 - Run harness up the tubes into fairing and use the strap to hold it in place.
- C.** Locate headlight harness and look for an ORANGE/WHITE wire with a female spade and connect male spade from harness to it. Could have a red cap on it?

Step 27

- If you want the L.E.D. in the dash, follow the instructions below. If you don't just tie off RED female bullet connector and no L.E.D.

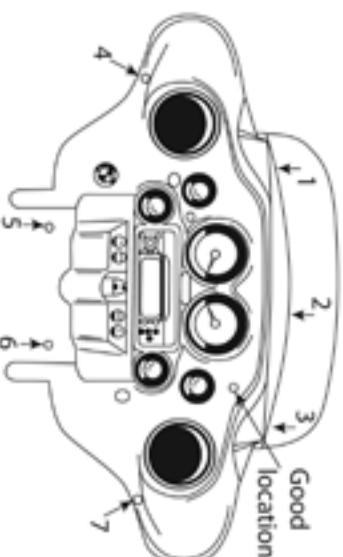

- Find a good location on the dash for L.E.D. Drill a 5/16" hole.
- Remove nut from L.E.D. and feed wires thru the hole. Replace nut and tighten.
- Measure RED L.E.D. wire to RED female bullet connector on harness. Strip wire and attach MALE bullet to a RED L.E.D. wire. Figure (D) below.
- Secure harness and wires with tie straps.

Checklist:

- Replace oil filter
- Check oil level
- Hoses tight
- Replace chrome cover
- Clean up any oil
- Check electrical
- Replace fairing
- Connect headlight
- Start bike - Let it idle.

Congratulations!

Text your pictures to
831-207-3394.



OIL COOLING SYSTEMS

1851 Airway Drive, Suite C, Hollister, CA 95023

TOLL-FREE: 888 630-1322

831-630-1322 **Fax:** 831-630-7024

Email: info@ultracoolfl.com

Web: ultracoolfl.com